

GENERALITÀ

- Prestazioni - Consumo carburante	1
------------------------------------	---

DATI TECNICI**MOTORE**





- Dati caratteristici	2
- Curve caratteristiche	3
- Dati per l'identificazione	3
- Basamento e organi del manovellismo	4
- Testa cilindri e organi della distribuzione	5
- Alimentazione	7

CAMBIO E DIFFERENZIALE	8
------------------------	---

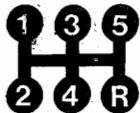
IMPIANTO ELETTRICO	9
--------------------	---

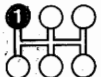
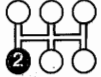
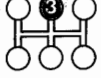
PER QUANTO NON TRATTATO IN QUESTO CAPITOLO ATTENERSI A QUANTO È DESCRITTO NEL RELATIVO CAPITOLO "GENERALITÀ E DATI TECNICI" DELLA PANDA 750 YOUNG".

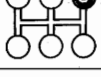
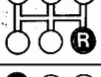
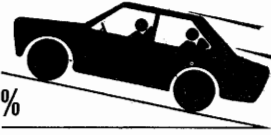
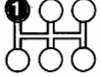
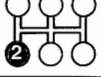
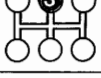
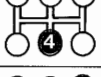
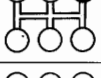
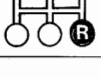
CAMBIO	
---------------	---



<p>Velocità km/h (a medio carico)</p> 		36
		68
		105
		135
		130
		38
	<p>Pendenza a massimo carico</p>  <p>%</p>	
		18
		11
		7
		5,5
		33
<p>Consumo carburante secondo norme ECE (litri/100 km)</p> 		Percorso urbano (A)
	Velocità costante 90 km/h (B)	4,8
	Velocità costante 120 km/h (C)	6,8
	Consumo medio (proposta CCMC) $\frac{A + B + C}{3}$	6,2



00.10

DATI CARATTERISTICI

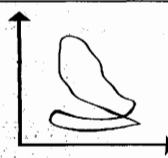

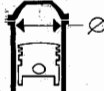
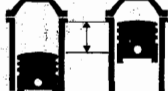
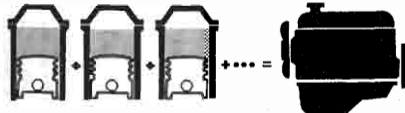
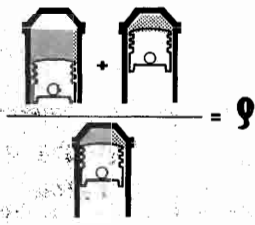
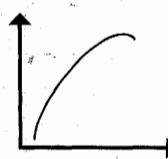
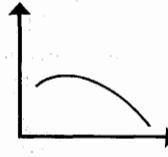
	Tipo	146 A.048
	Ciclo	OTTO 4 tempi
	Numero cilindri	4
	Canna cilindro (alesaggio)	mm 65
	Corsa	mm 68
	Cilindrata	cm ³ 902,58
	Rapporto di compressione	9 ± 0,15
	Potenza massima CEE	kW (CV) 33,1 (45)
		1/min 5600
	Coppia massima CEE	daNm (kgm) 6,7 (6,8)
		1/min 3000

Curve caratteristiche dei motori rilevati con il metodo CEE

Le curve di potenza illustrate sono quelle ottenibili a motori revisionati e rodati, senza ventilatore, con silenziatore di scarico e filtro aria, al livello del mare.

Cicli di prova al banco dei motori revisionati

Nella prova al banco dei motori revisionati, non è consigliabile portare i motori a regime massimo, ma attenersi ai dati prescritti nella tabella; completare il rodaggio dei motori stessi sulle vetture.

Regime di prova (1/min)	Tempo in minuti	Carico al freno
800 ÷ 1000	10'	a vuoto
1500	10'	a vuoto
2000	10'	a vuoto

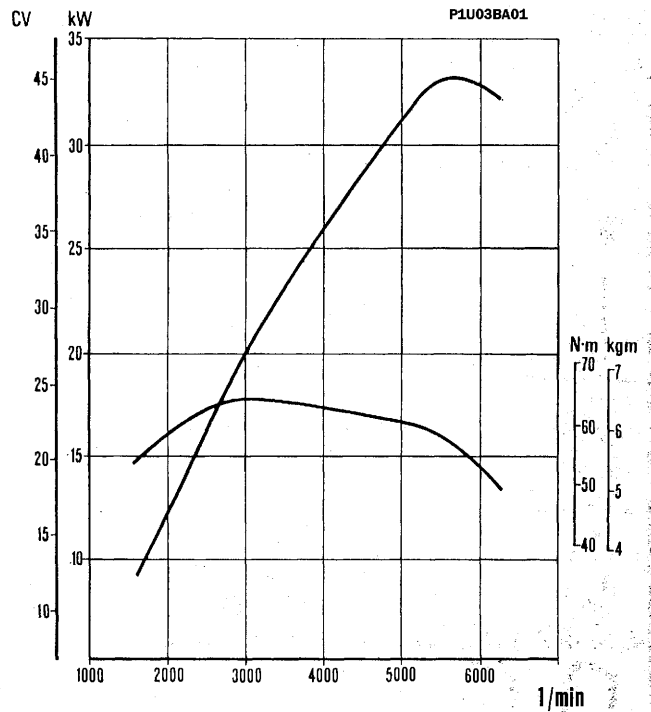





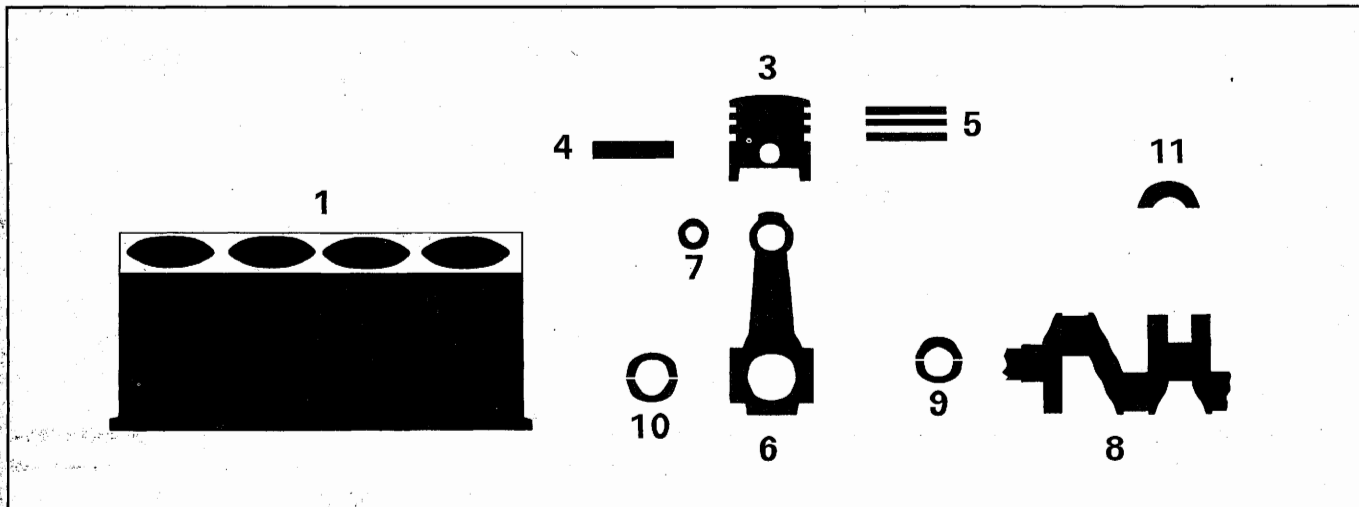

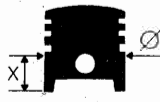

DATI PER L'IDENTIFICAZIONE

	AUTOTELAIO	MOTORE	VERSIONE	Cambio a 5 marce
	ZFA 141A.000	146 A.048	141 AL 53A	●



MISURE E ACCOPPIAMENTI

			Valori in mm
3  Stantuffo		X	14,5
		A	64,940 ÷ 64,950
		C	64,960 ÷ 64,970
		E	64,980 ÷ 64,990
		 >	0,4
3 	Differenza di peso fra stantuffi		± 3,5 g
3-1 	Stantuffo Canna cilindro		0,050 ÷ 0,070
5-1  Apertura estremità anelli nella canna cilindro		1	0,20 ÷ 0,45
		2	0,20 ÷ 0,35
		3	0,20 ÷ 0,45
9-8 	Cuscinetti di banco - Perni		0,026 ÷ 0,071
10-8 	Cuscinetti di biella - Perni		0,026 ÷ 0,084

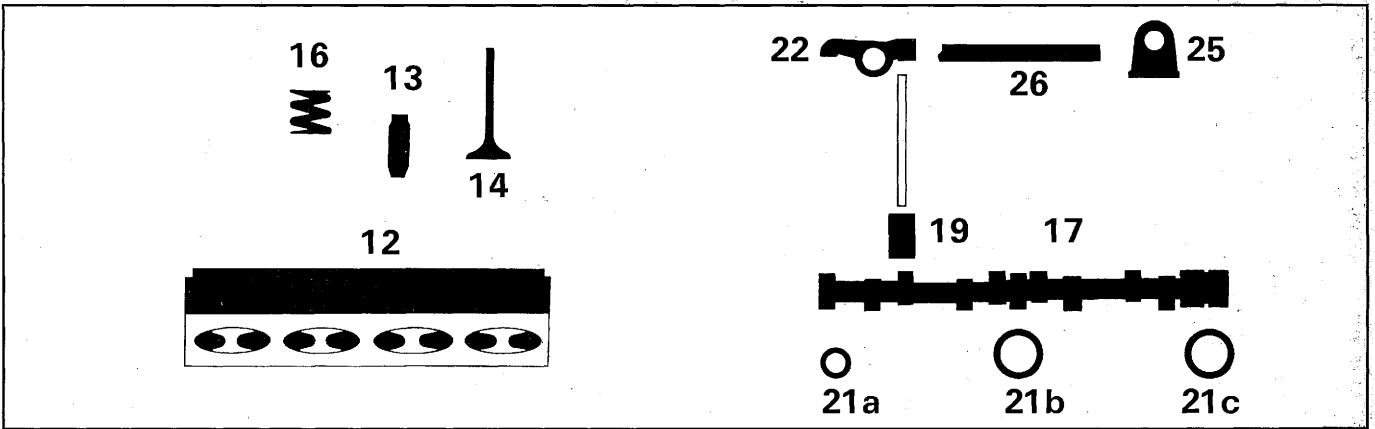

MISURE E ACCOPPIAMENTI

Valori in mm









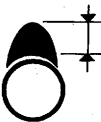

	<p>Volume della camera di combustione nella testa cilindri</p>	<p>cm³</p>	<p>22,5</p>		
	<p>Alzata camma</p>		<p>7,65</p>		
<p>22-14</p>		<p>per controllo messa in fase</p>			<p>0,60</p>
<p>di funzionamento</p>			<p>0,15 ± 0,05</p>		
	<p>0,20 ± 0,05</p>				

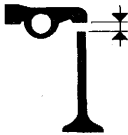
DIAGRAMMA DELLA DISTRIBUZIONE

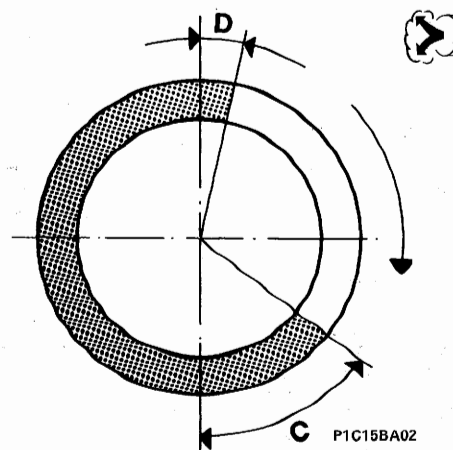
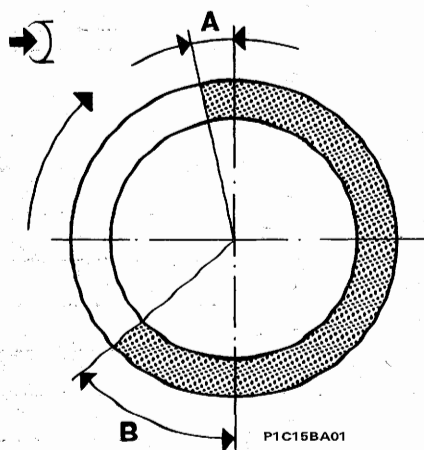

ANGOLI DI FASATURA

A	Aspirazione 	inizio prima del PMS	7°
B		fine dopo il PMI	36°
C	Scarico 	inizio prima del PMI	38°
D		fine dopo il PMS	5°







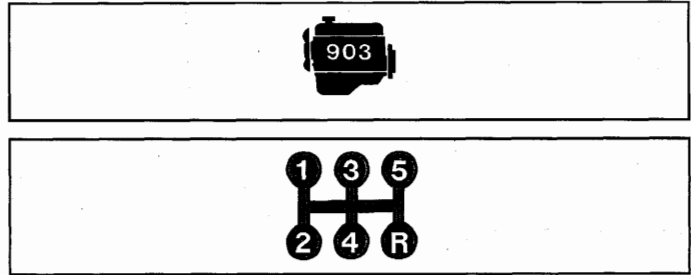



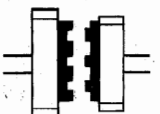

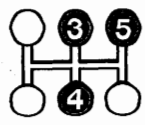

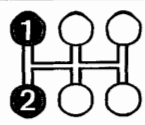
CARBURATORE
WEBER
32 ICEV
61/250

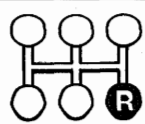
Diffusore	mm	22	
Centratore	mm	3,5	
Getto principale	mm	1,10	
Getto aria di freno	mm	1,80	
Tubetto emulsionatore		F 74	
Getto minimo	mm	0,47	
Getto aria minimo	mm	1,60	
Foro irreversibilità	mm	1,00	
Progressione	1° foro	mm	1,00
	2° foro	mm	1,00
	3° foro	mm	1,00
	4° foro	mm	1,00
	5° foro	mm	-
Asola progressione	mm	-	
Foro continuità	mm	-	
Foro registro miscela minimo	mm	1,50	
Boccola miscela minimo	mm	1,30	
Getto sovralimentatore	mm	0,70	
Getto miscela sovralimentatore	mm	2,50	
Getto pompa	mm	0,40	
Scarico pompa	mm	0,40	
Portata pompa (10 pompate)	cm ³	3,8 ÷ 6,3	
Getto di piena potenza	mm	0,50	
Boccola capsula sgolamento	mm	0,70	
Sgolamento minimo	mm	4,25 ÷ 4,75	
Sgolamento pneumatico avviamento a freddo	apertura minima	mm	-
	apertura massima	mm	-
Minimo veloce	mm	0,75 ÷ 0,80	
Valvola a spillo	mm	1,50	
Livello meccanico con guarnizione	mm	10,50 ÷ 11,00	
Corsa galleggiante	mm	-	
Foro ricircolo carburante	mm	1,00	
Foro anticipo	mm	-	

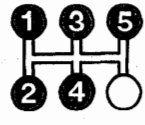

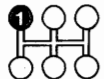
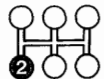
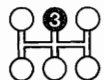
00.21-27

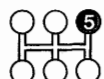

CAMBIO DI VELOCITÀ

 Sincronizzatori	ad anello elastico (tipo Porsche) 	
	ad anello libero 	
 Ingranaggi	a denti diritti 	
	a denti elicoidali 	
 Rapporto ingranaggi		3,909
		2,056
		1,344
		0,978
		0,837
		3,727

DIFFERENZIALE

 	Rapporto coppia cilindrica di riduzione	13/55 (4,231)
---	---	------------------

MOTORE D'AVVIAMENTO	M. Marelli E76 - 0,6 kW - 12 V
ALTERNATORE	M. Marelli AA125R - 14 V - 45A
REGOLATORE DI TENSIONE	Elettronico incorporato M. Marelli RTT 119 AC
BATTERIA	32 Ah - 12 - 150 A
DISTRIBUTORE D'ACCENSIONE	M. Marelli S 177 AX Ducellier 525343A
ROCCHETTO D'ACCENSIONE	M. Marelli BE 200 B Boch 0.221.119.048 Klitz OEM G 52 S Iskra ATA 1710
CANDELE	FIAT V4 LSR M. Marelli F7 LCR Champion RN 9 YC Bosch WR7 DC